

EQUO SOFT LIGHT MAXI



DESCRIZIONE/DESCRIPTION

Gli addolcitori EQUO SOFT LIGHT si avvalgono di una centralina computerizzata che fornisce all'utente tutte le informazioni sulla programmazione ecc. Sono provvisti di sistema automatico di rigenerazione delle resine, in modalità TEMPO/VOLUME. By-PASS fornito di serie.

The water softeners EQUO SOFT LIGHT use a computerized control unit that provides the user with all the information on programming. They are equipped with automatic regeneration resins system, TIME/VOLUME Mode. BY PASS included as standard.



Operazioni di manutenzione e smontaggio semplici ed immediate.
Disassembly and maintenance simply and immediate.



CARATTERISTICHE TECNICHE

- Stampaggio a iniezione;
- 100% materiale non tossico, riciclabile e per uso alimentare (PP), conforme a D.M. 174/04;
- Bombola indipendente dal pozzetto, in vetroresina e connessione da 2" 1/2;
- Estrema facilità di manutenzione e pulizia senza la necessità di disassemblare la struttura;
- La parte superiore, estraibile, consente la completa accessibilità al vano del pozzetto senza dover rimuovere la valvola;
- Resina cationica per addolcitore inclusa. Indice nominale 5500/150;
- Capacità contenitore salamoia: 78 Lt (150 Lt per bombole 13");
- Valvola elettronica da 3/4" con BY-PASS integrato, RUNXIN F79;
- Rigenerazione in controcorrente;
- Alimentazione: 230 VAC 50Hz;
- Pressione di esercizio: 2 - 6 BAR (29 - 87 PSI);
- Temperatura d'esercizio: 5° - 42°C (41F°-107F°);
- Test invecchiamento: 100.000 cicli - 0-12 BAR;
- Colori standard: cabinato bianco/grigio, bombola blu;
- Menù valvola in italiano e altre 9 lingue.

TECHNICAL FEATURES

- Injection moulded;
- 100% non-toxic, recyclable and food grade material (PP), in conformity Italian Ministerial Decree 174/04;
- Unique brine/pressure vessel separation chamber. Pressure vessel in fiberglass and inlet size 2" 1/2;
- Easy clearing and maintenance without disassembling the system;
- Detachable salt lid for easy accessibility to brine compartment without removal of valve;
- Cation exchange resin included. Par value 5500/150;
- Brine capacity: 78 Lt (150 Lt for 13" vessel);
- Electronic valve 3/4" with BY PASS included, RUNXIN F79;
- Upflow regeneration;
- Power supply: 230 VAC 50 Hz;
- Working pressure: 2 - 6 BAR (29 - 87 PSI);
- Working temperature: 5° - 42°C (41F°-107F°);
- Cycle test: 250.000 cycles - 0-12 BAR;
- Standard color: white/grey cabinet, blue tank;
- Valve menù in italian and other 9 languages.

N.B.: dati medi rilevati a 25°C e 2 BAR di pressione/Average data recorded on 25°C and 2 BAR pressure.

Codice Code	Modello Model	Formato bombola Pressure vessel size	Capacità Resina (Lt)* Resin capacity (Lt)*	Capacità ciclica (M ³ /F°) Cyclic capacity (M ³ /F°)	Consumo medio di sale per rigenerazione (Gr) Average salt consumption per regeneration (Gr)	Portata consigliata (m ³ /h) Flow-Rate recommended (m ³ /h)	Imballo / Pack			Price (€)
							Singol	Multiple	Pz.	
A9981020	Equo Soft Light Maxi	8"x35"	20,0	110,0	3000	0,7	420x620x1100H	420x620x1100H	1	
A9981030		10"x35"	28,0	154,0	4200	1,0	420x620x1100H	420x620x1100H	1	

Versione PK a richiesta/PK version on request

* Riempimento considerato 4/5 del volume utile/Filling considered 4/5 of available volume.

** Con tino sale separato/With separated salt tank



DIMENSIONI/DIMENSIONS:

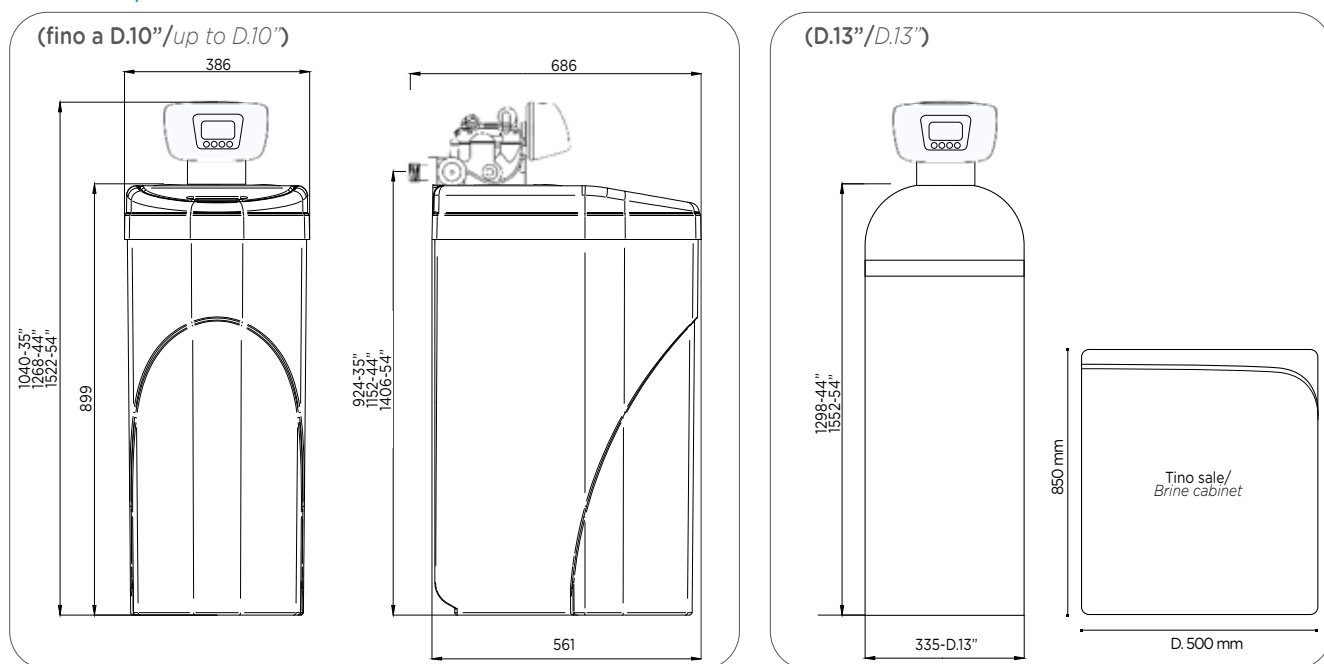

RICAMBI E ACCESSORI/SPARE PARTS AND ACCESSORIES



Codice Code	Descrizione Description	Price (€)
S9700030	Pozzetto di aspirazione/Brine well	
S9700010	Paratia (A richiesta)/Partition grid (On request)	
A9990030	Ghiera troppo pieno 3/8"/3/8" Nut for overflow system	
A9990040	Raccordo troppo pieno 3/8"/3/8" Connection for overflow system	
A9700000	Coprivalvola con adattatore di coperchio (Su richiesta)/Valve cover (On request)	
S6070260	Imbuto riempimento resine (Su richiesta)/Resin filling funnel (On request)	
A9990180	Valvola sicurezza salamoia. Solo su versione con paratia (A richiesta)/Safety brine valve. Only on version with Partition grid (On request)	
MC030120	1 sacco da 25Lt di resina cationica per addolcitore (A richiesta)/1 bag of 25Lt cation exchange resin (On request)	
MC020130	1 sacco da 25Kg di sale per addolcitore (A richiesta)/1 bag of 25Kg water softener salt (On request)	
A9950045	Generatore di Cloro (A richiesta)/Chlorine generator (On request)	



Bombola VTR.
Pressure vessel VTR.



Versione standard.
Standard version.



Versione a richiesta con paratia (PK).
On request version with partition grid (PK).